

# F51M1-0900 SPECIFICATIONS

## 51 collection series 900 box frame mirror with vertical LED lighting

### FEATURES:

- Box perimeter frame mirror with two vertical LED lights + infrared switch
- 110V strip LED 9.6W/MT RV4200K
- Frame serves as an integral shelf
- Integral channel on the back for ease of installation:  
allows installer to adjust brackets to hit studs accordingly
- Made of IDROLEB ECOLOGICAL PANEL with  
the lowest formaldehyde emissions in the world
- IDROLEB also ensures defence against humidity
- Italian-crafted for superior quality

### SPECIFICATIONS:

Dimensions:	(WHD) 35½" x 25¼" x 5" (900mm x 643mm x 125mm)*
Weight:	22lbs (10kg)*
Materials:	White Lacquer: MDF
Warranty:	Five Year Limited Warranty (Residential) One Year Warranty (Commercial)
Shipping Weight:	27.5lbs (12.5kg)*
Shipping Dimensions	(WHD) 37½" x 27¼" x 7" (950mm x 690mm x 175mm)*

### STOCKED COLOR/FINISH:

Lacquer

01M  
White  
Matte

### INSTALLATION NOTES:

Install this product according to the installation guide.  
Our products must be installed by professionals only  
and according to our installation guide as well as federal,  
provincial / state and local building codes and regulations.

### CODES:

- Meets or exceeds UL/ULC, and CSA requirements
- CSA 22.2
- UL/ULC 962
- UL/ULC 8750

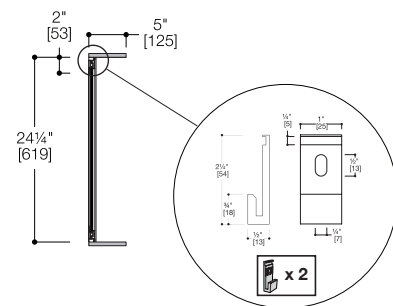
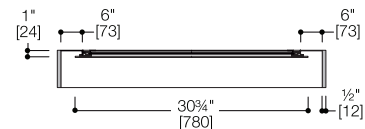
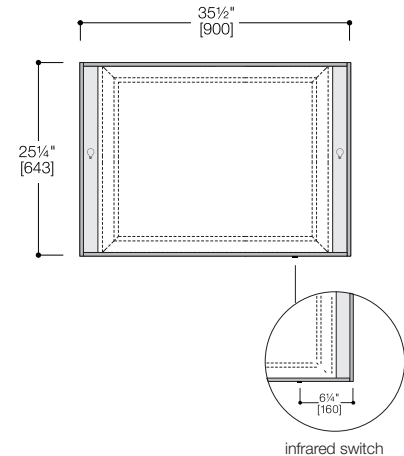

\*Approximate measurements for comparison only.

**Note:** These dimensions and specifications are subject to change without notice.