

Slimline Mixer TH

by JEE-O

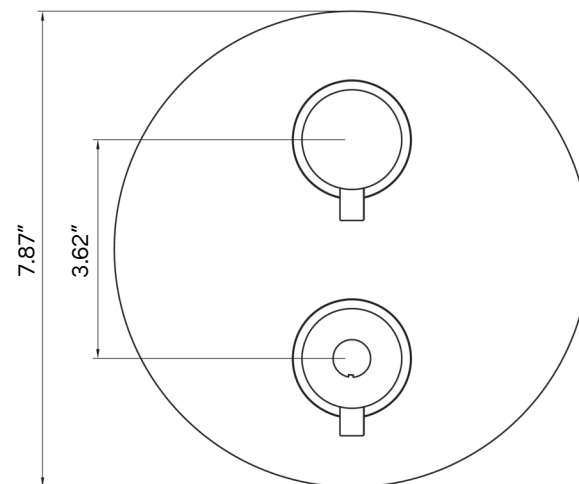

- brushed
800-2300
- structured black
800-2303



SPECIFICATIONS

MATERIAL:	304 stainless steel
FEATURES:	thermostatic mixer three-way diverter
CARTRIDGES:	thermostatic mixing mechanism (#005-0501) ceramic diverter mechanism (#005-0601)
WEIGHT:	7 lbs
PACKAGE DIMENSIONS:	L 10" x W 9" x H 8"
DELIVERY WEIGHT:	8 lbs
WARRANTY:	2-year limited warranty

MAINTENANCE & CARE

BRUSHED:	Regularly apply stainless steel cleaner and rub in the direction of the grain, using a slightly abrasive sponge.
STRUCTURED BLACK:	Regularly clean with soap water or alcohol. Do not use abrasives.

